

1 Install Lock Body

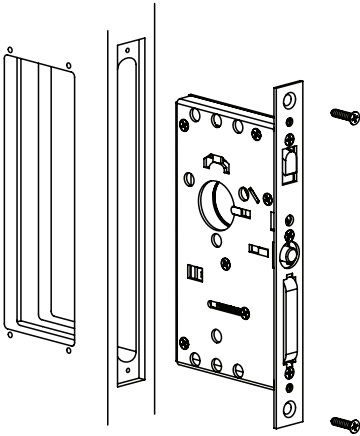

See template for door prep specifications

2 Install Drive Bar Cylinder

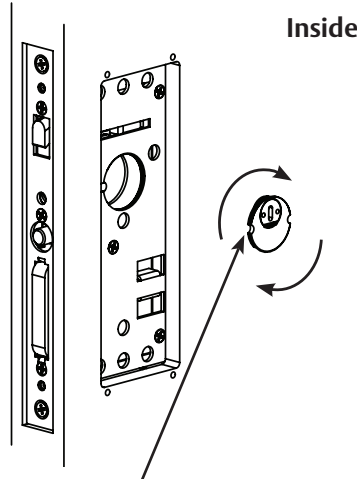

Note: Notch on cylinder must be in the 9 o'clock position when fully screwed into lock body.

3 Mount Inside Plate

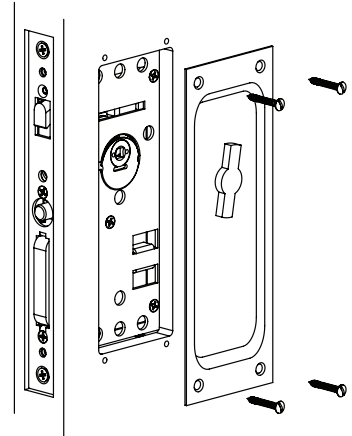

4 Mount Outside Plate

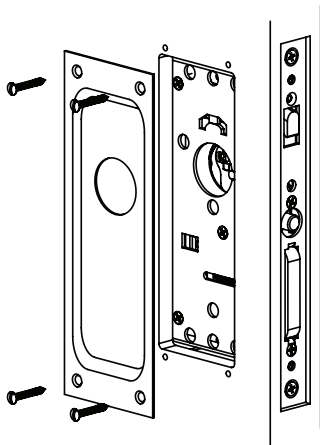

5 Thread Key Cylinder

Install Key Cylinder by threading it clockwise onto lock body plate

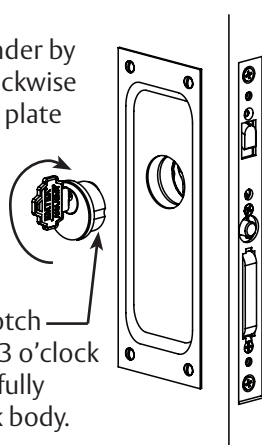

Key Cylinder notch must be at the 3 o'clock position when fully screwed in lock body.

6 Tighten Drive Bar Cylinder

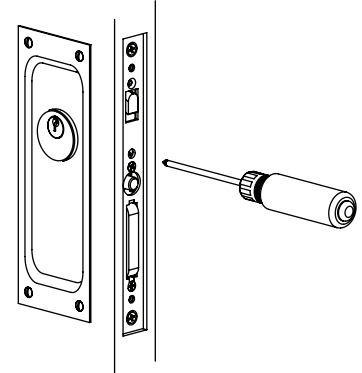

Tighten locking screw to engage notch on cylinder

7 Install Trim Plate

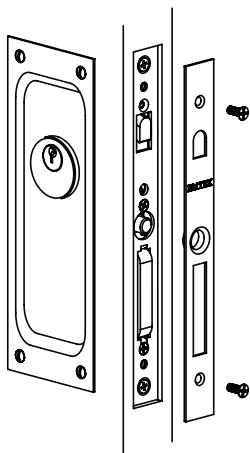

8 Install Door Jamb

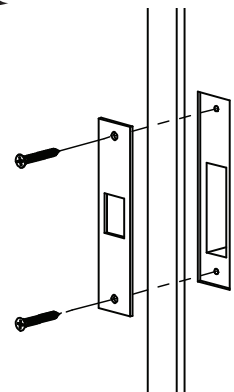

Drill two 7/64" pilot holes

See template for door jamb prep specifications

1 Install Lock Body

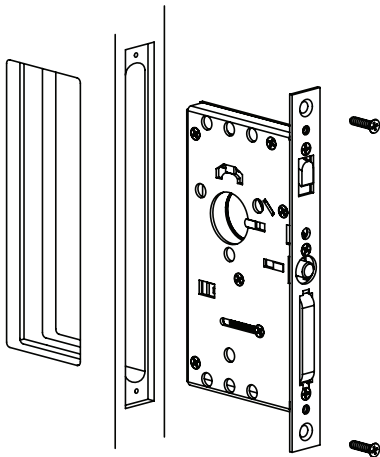

See template for door prep specifications

2 Install Drive Bar Cylinder

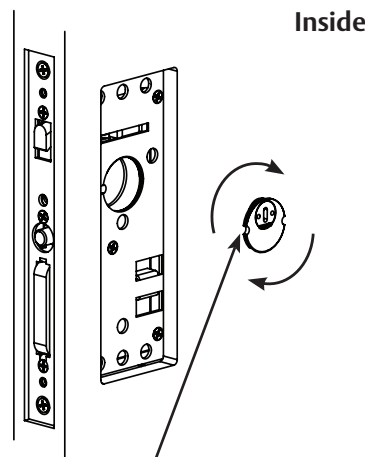

Note: Notch on cylinder must be in the 9 o'clock position when fully screwed into lock body.

3 Mount Inside Plate

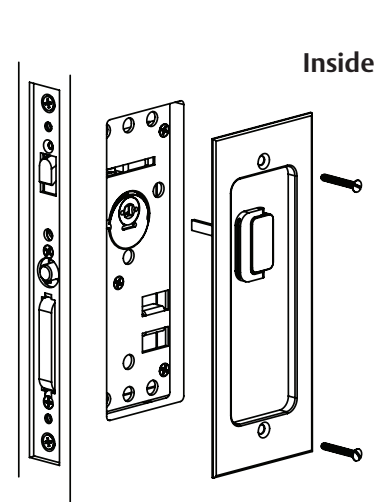

4 Mount Outside Plate and Thread Key Cylinder

Install Key Cylinder by threading it clockwise onto lock body plate

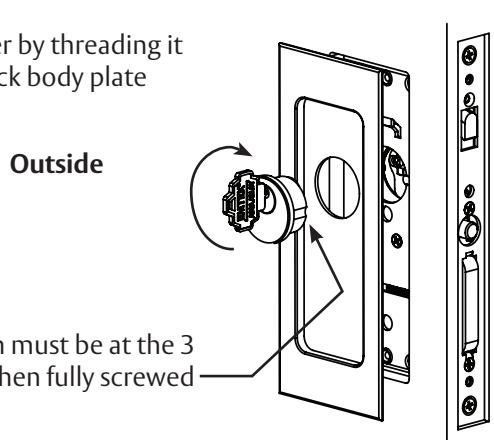

Key Cylinder notch must be at the 3 o'clock position when fully screwed in lock body.

5 Tighten Drive Bar Cylinder

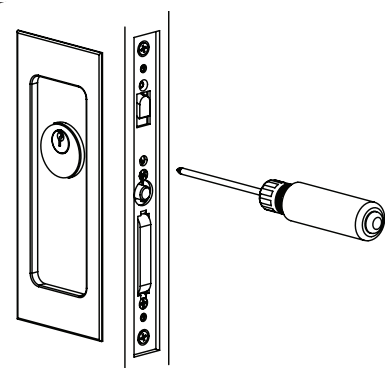

Tighten locking screw to engage notch on cylinder

6 Install Trim Plate

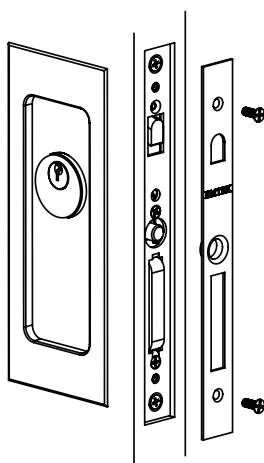

7 Install Door Jamb



Drill two 7/64" pilot holes

See template for door jamb prep specifications